



Addressing Complex Challenges
With Rundown Blending in
Aspen Refinery Multi-Blend Optimizer™

Over time, spreadsheets often fall short in accurate property calculations, inventory visualization and the overall collaboration with other schedulers.

Background

The benefits of strategic and tactical refinery operations planning are well established in the downstream market. Planning tools such as Aspen PIMS™ are used to generate blending targets, which are later passed to the refinery scheduler. However, these targets can be difficult to achieve and often represent an average for the planning period. They also don't account for operational constraints such as tank ullage, discrete blend events, operational variance and disturbances, product tank heels and more.

AspenTech is the leading supplier of petroleum supply chain software, with almost half of the market share.

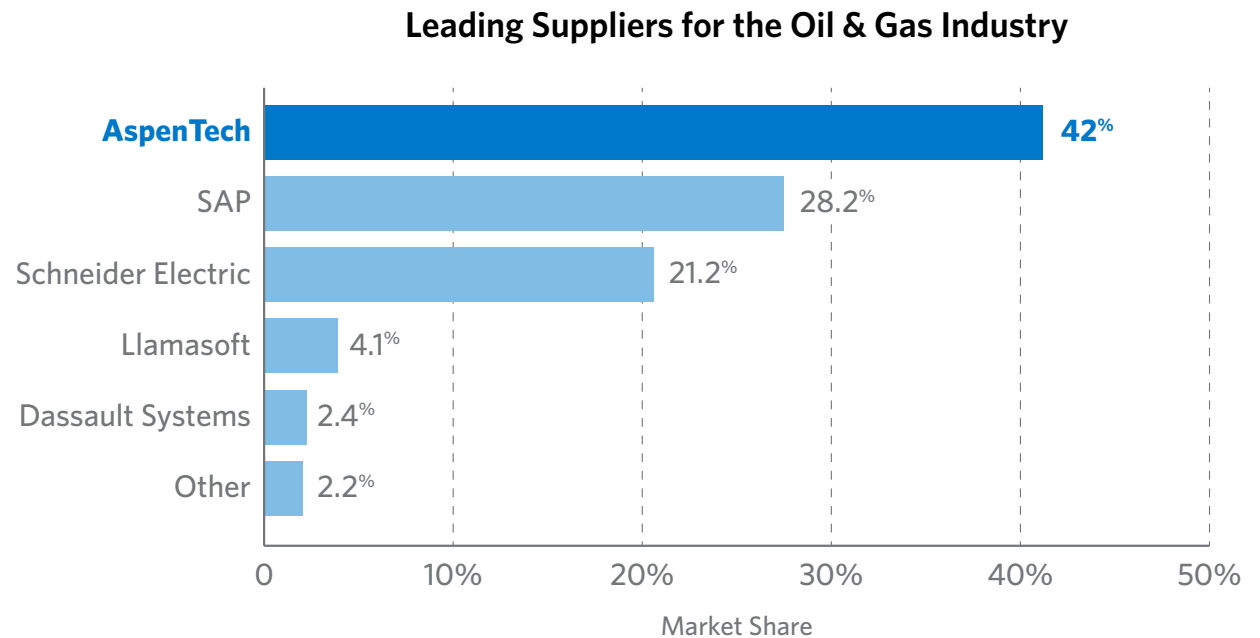

Source: ARC Advisory Group, 2017 Supply Chain Planning Global Market Research Study: Market Analysis and Forecast through 2022



The Importance of a Blending Solution

Today's refineries face many different challenges when it comes to downstream scheduling while striving to maximize margins and meet market and regulatory requirements. The cost of feedstocks, stricter product specifications and variable operating targets introduce the possibility to produce off-spec products, decrease margins and decrease operational infeasibilities. While market trends continue to change, refinery schedulers are tasked to produce optimal schedules which are both operationally sound and optimally feasible.

Typically, a refinery scheduler's role is primarily executed via a number of different spreadsheets. Initially, this course of action is inexpensive to

the refiner; however, spreadsheets often fall short over time in accurate property calculations, inventory visualization and the overall collaboration with other schedulers. As the blend complexity increases and additional constraints are introduced — for example, limited component tankage — the challenge often quickly turns to generating a feasible schedule and recipe with little to no optimization. In circumstances like these, a scheduler's responsiveness becomes paramount and further highlights the need for a powerful and reliable blend scheduling automation tool to handle these complex challenges, much like Aspen Refinery Multi-Blend Optimizer (MBO) does, and help reduce any re-blends and product quality giveaways.

What is Aspen Refinery Multi-Blend Optimizer?

Aspen Refinery Multi-Blend Optimizer is an event-based, multi-period and multiblend modeling system that generates optimal blending schedules for short and long-term campaigns. MBO generates and solves non-linear blending problems that span a user-defined time period. It takes into account correlations, tank constraints, discrete volumes, recipe constraints and all relevant events such as blends, timing and sequencing of rundown blends, product shipments, intermediate receipts and tank-to-tank transfers.

MBO is tightly integrated with Aspen Petroleum Scheduler™ (APS) and allows for collaborative, event-driven blend scheduling and optimization. MBO can be implemented as a standalone system or with APS to optimize blending using the latest refinery schedule that incorporates an online blend control interface (BCI). This collaborative nature of MBO enables different users (e.g., gasoline blender and distillate blender) to generate a refinery-wide blend schedule on a single database, while retaining visibility into inventories and restricting access and/or modification to those without sufficient permissions.

Key Benefits

- Improves margins by using the optimal combination of static and rundown components
- Eliminates off-spec blends
- Reduces blend recipe and blend quality giveaway
- Decreases holding costs and component stockouts
- Increases collaboration between planners, schedulers, and traders
- Improves visibility of current and predicted tank volumes and properties



The Rundown Challenge

In the context of refinery blending, rundown blending consists of taking a unit stream straight into the finished product tanks. In other words, rundown blends are simply blends whose recipes use components with no intermediate tankage between the process unit and blender. Refiners have started to look more into this blending method for a few reasons: a lack of real estate onsite to build additional intermediate units and finished product tanks, the high cost to build new tanks and maintain, and the cost that comes with having finished products in storage — a refiner doesn't benefit from storing finished product onsite. On the contrary, the key objective of the refiner is throughput and to keep products moving to remain profitable.

These rundown blends pose a significant logistical challenge as schedulers continuously address flowing rundowns and discrete product blends. These challenges could lead to a number of questions:

1. What product grade should be blended?
2. When should it be blended?
3. What is the optimal recipe?
4. Where will the rundown be directed? (In the case of an operational disturbance.)

One thing remains certain — conventional blend scheduling remains complicated with the absence of intermediate tankage. However, when additional degrees of freedom are introduced, such as multiple destinations for a rundown(s) or a slop tank(s), the potential number of feasible solutions increase.

Sometimes a scheduler may miss a more profitable schedule after converging on the first feasible solution. Hence, there is a compelling business need for a fast and transparent tool to not only find these solutions, but to also deliver an operationally and economically optimal schedule.

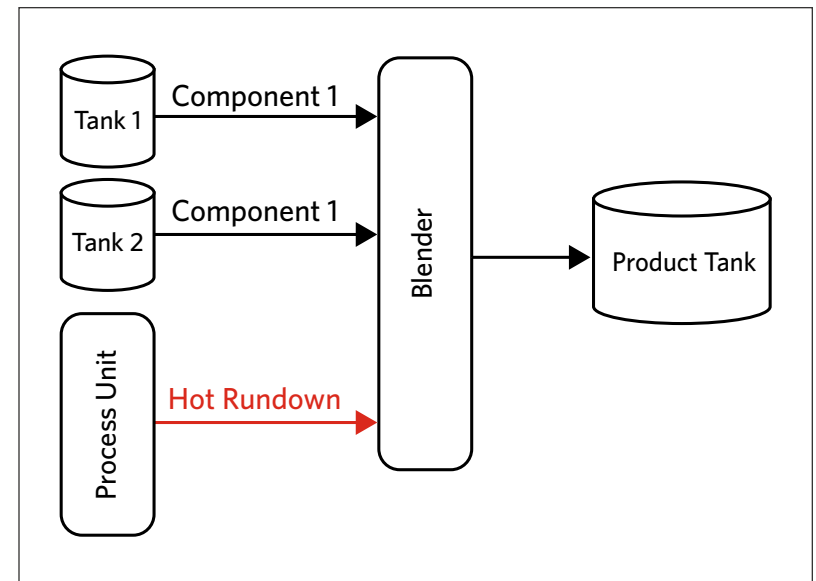

Rundown Blending Scenario 1: Blend using a hot rundown stream.



Optimizing Rundown Blends With Aspen Refinery Multi-Blend Optimizer

MBO addresses the following rundown blending scenarios:

1. Blends using a hot rundown stream
2. Blends using a hot rundown stream with multiple, fractional dispositions
3. Blends utilizing a hot rundown stream with an available slop tank

Each of these scenarios can be modeled and solved in parallel within MBO. The first scenario requires rigid handling of rundown streams. To avoid a material infeasibility, the stream must always be participating in a blend. The second and third scenarios introduce the concept of optimizing splitter units within MBO. Splitters can be placed between process units and blenders to introduce additional degrees of freedom to the optimizer. With the capability to perform these three scenarios, MBO is well-equipped to help schedulers tackle the complex refinery blending challenges that may arise in their day-to-day job.

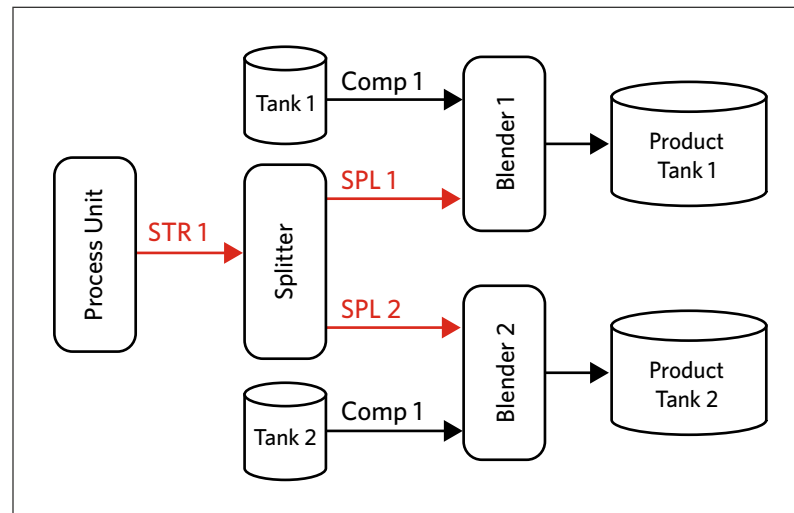

Rundown Blending Scenario 2: Blend using a hot rundown stream with multiple, fractional dispositions.



Rundown Blending Windows

MBO's rundown blending has the groundbreaking capability to optimize both blend timing and sequencing. Each rundown blend event in MBO will have a period of time in which a blend may occur, which is referred to in MBO as a "blend window."

Exclusive Blenders

MBO supports user-defined constraints on blenders to prevent the overlap of rundown blend events. Coupled with rundown blending windows, MBO can converge to a solution that determines the optimal sequencing of contiguous rundown blends through a blender.

Granular Component Rundowns

MBO supports period-by-period changes in rundown flows and properties. With rundown blending, there is a greater need for granular assignment of flows and properties. Additionally, splitter dispositions are defined on a periodic basis and may have properties that differ from the feed.

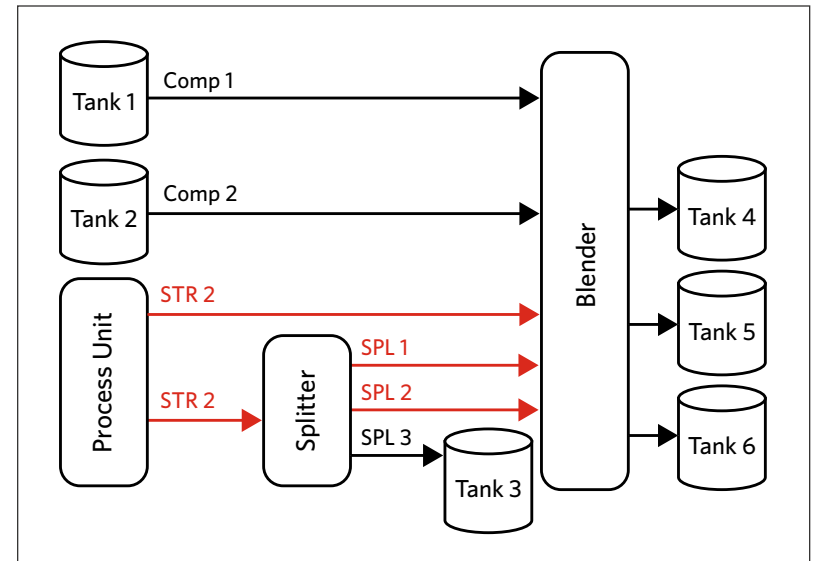

Rundown Blending Scenario 3:
Blend utilizing a hot rundown with an available slop tank.

Example: Implementing Rundown Blending in an Existing Model

An operating company is interested in expanding their existing distillation blending model in MBO to represent an actual rundown blending scenario. In this model, hydrotreated middle distillates from the crude tower are stored in a component tank used in batch blending events. In actuality, these treated distillates are hot rundowns with slop tanks to handle times of component excess. In order to quickly analyze the benefits of rundown blending optimization in MBO, this operating company intends to quickly add rundown blending optimization to the model.

Fortunately, rundown blending can be quickly added to an existing MBO model with the following steps:

1. Create new components to represent the splitter stream dispositions
2. Create or assign existing APS splitters to handle rundown stream disposition
3. Add the trends and splitter control variables to the Gantt Screen
4. Modify blends to use either the hot rundown or slop tank components

1. Create new components to represent the splitter stream dispositions

First, create new components to represent the possible stream dispositions. In this scenario, the model has the kerosene and diesel hydrotreaters feeding the component tank directly.

The existing component tanks will need to be converted to slop tanks. This requires no change to the tank, but does require the addition of new streams and a splitter between the process units and the blender.

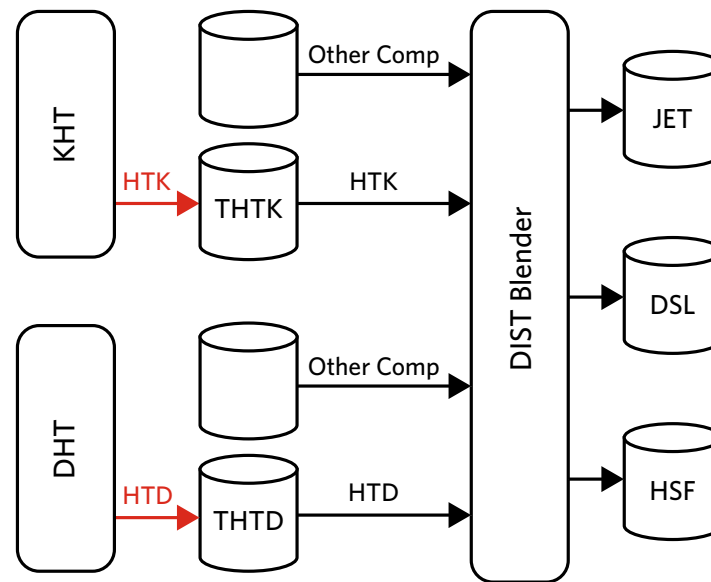

Create new components to represent possible stream dispositions.

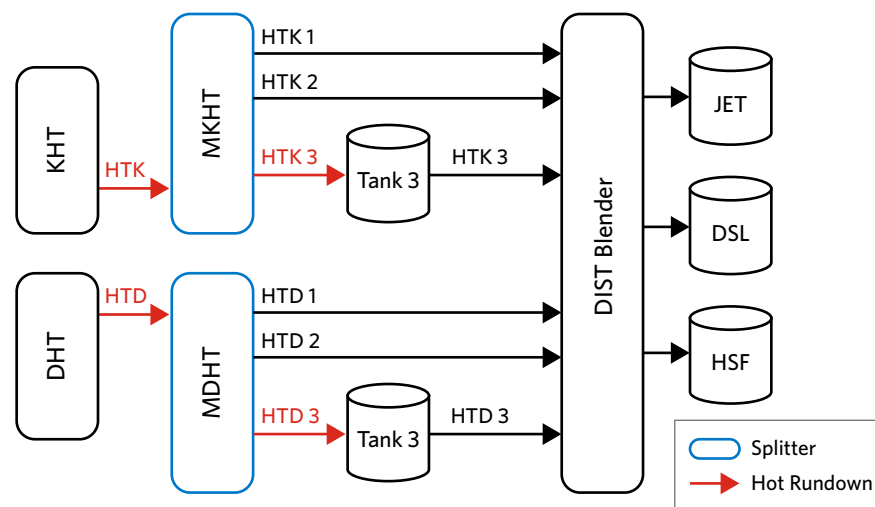

Convert existing component tanks to slop tanks.

2. Create or assign existing APS splitters to handle rundown stream disposition

The splitters can be added from a new dialogue within MBO. The splitters dialogue can be found under **Model > Splitters**.

Within this dialogue, a new splitter can be defined or an existing splitter selected. Stream dispositions will be selected and volume MIP constraints will be applied to the splitter dispositions.

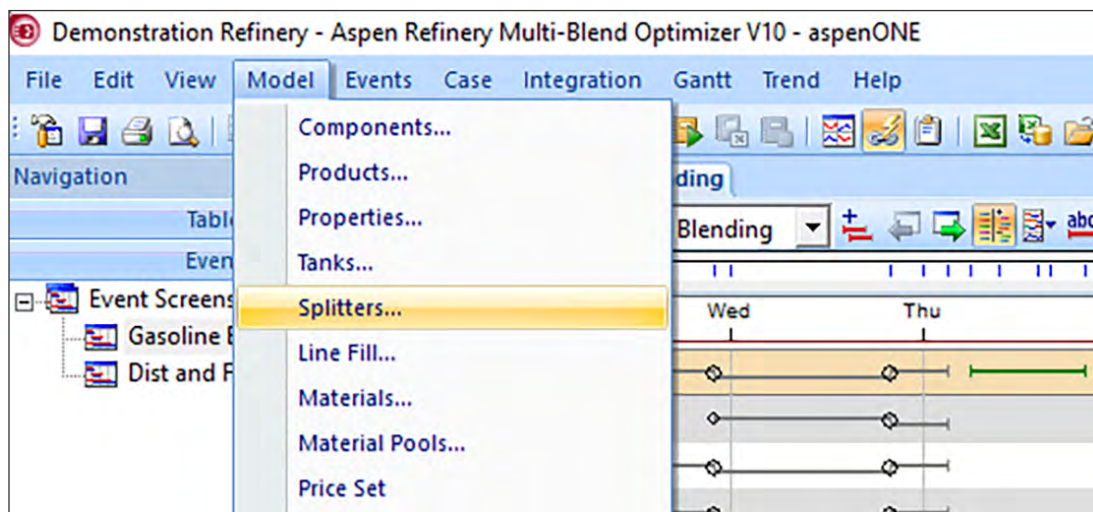

To create a new splitter or change an existing splitter within Aspen Refinery Multi-Blend Optimizer, select Model, then Splitters.

3. Add the trends and splitter control variables to the Gantt Screen

4. Modify blends to use either the hot rundown or slop tank components



Conclusion

The refining market is ever-evolving due to market trends continuously changing. Typically, refiners use spreadsheets to develop a schedule, but are often limited to time-based scheduling due to spreadsheet limitations. With the growing environmental regulations, product specifications and lack of intermediate units and finished product tanks, refiners have shown much interest in the rundown blending method.

In Aspen Refinery Multi-Blend Optimizer, schedulers use rundown components continuously, while respecting tank inventories and constraints to generate a refinery-wide blend schedule on a single database. Advantages of Aspen Refinery Multi-Blend Optimizer's rundown blending technology include:

- Stable optimization of highly non-linear operations
- Tight integration with Aspen PIMS and Aspen Petroleum Scheduler, the industry leaders in refinery planning and scheduling
- Immediate visibility into rundown infeasibilities and expected splitter dispositions
- Reduced off-spec blends, re-blends and product quality giveaway
- Decreased holding costs and component stockouts

These benefits provide refiners with a competitive advantage and help maximize margins from available component streams, while meeting all market and regulatory requirements.

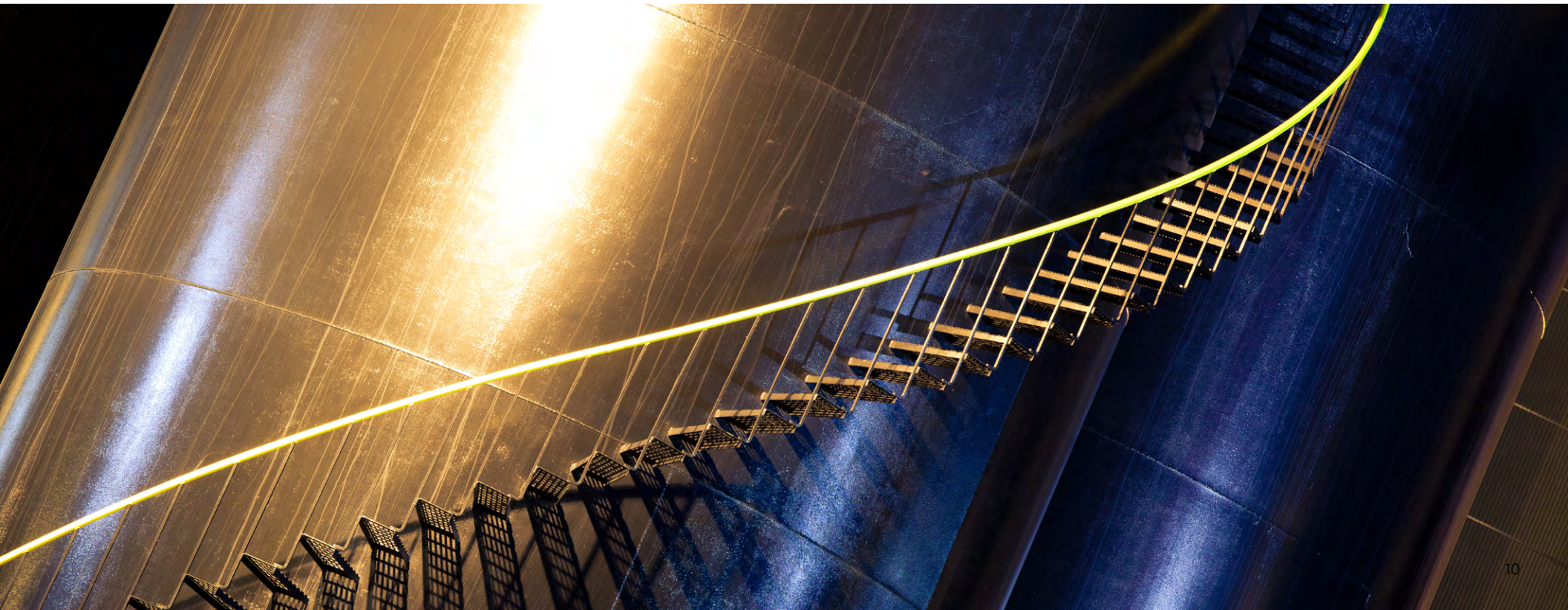

AspenTech is a leading software supplier for optimizing asset performance. Our products thrive in complex, industrial environments where it is critical to optimize the asset design, operation and maintenance lifecycle. AspenTech uniquely combines decades of process modeling expertise with machine learning. Our purpose-built software platform automates knowledge work and builds sustainable competitive advantage by delivering high returns over the entire asset lifecycle. As a result, companies in capital-intensive industries can maximize uptime and push the limits of performance, running their assets faster, safer, longer and greener.

www.aspentech.com

